

INTERRUPTED WALL FOR POSITION SIZES 6 AND ABOVE

- 1 MATERIAL
HOUSING: THERMOPLASTIC POLYESTER, GLASS FILLED, DR-48. UL94V-O.
POST: COPPER ALLOY
- 2 FINISH
HOUSING: BLACK
POST: BRIGHT TIN-LEAD (93/7) 0.00380 [.000150]-0.00880 [.000350] THICK OVER NICKEL UNDERPLATE 0.00130 [.000050] MINIMUM THICK OR MATTE TIN PLATE 0.00380 [.000150] THICK OVER NICKEL UNDERPLATE 0.00130 [.000050] MINIMUM THICK IF LEAD FREE.
- 3 UL MARKING MAY NOT APPEAR ON THE 3 POSITION SIZE.
- 4 POST SOLDERTAILS COMPLY WITH AMP SOLDERABILITY SPEC 109-11-2.
- 5 POST WITHSTANDS 13.34N (3 LB) MIN AXIAL FORCE IN EITHER DIRECTION WITHOUT DISLODGING.
- 6 APPLIES AT -A-.
- 7 APPLIES WHEN THE HEADER IS STRAIGHT.
- 8 PLASTIC PROJECTIONS PERMITTED IN THIS ZONE.
- 9 COORDINATE DIMENSIONS APPLIES FROM THE CENTER OF THE ACTUAL FEATURE.
- 10 SOLDER SIDE OF BOARD IS SHOWN.
- 11. DIMENSIONS IN BRACKETS ARE IN INCHES.
- 12 ALL POSITION SIZES HAVE THE BACK WALL NOTCHED ON BOTH ENDS AS SHOWN. THE 2 THRU 5 POSITION SIZES HAVE SOLID BACK WALLS. POSITION SIZES 6 AND ABOVE HAVE AN INTERRUPTED BACK WALL AT VARIOUS LOCATIONS (SEE TABLE FOR INTERRUPTION(S) LOCATIONS).
- 13 EDGE OF POLARIZING LOCK WALL TO BE IN LINE WITH CENTERLINE OF ADJACENT POST WITHIN ±0.13 [.005].
- 14 NOTCH SHOWN MAY OR MAY NOT APPEAR.

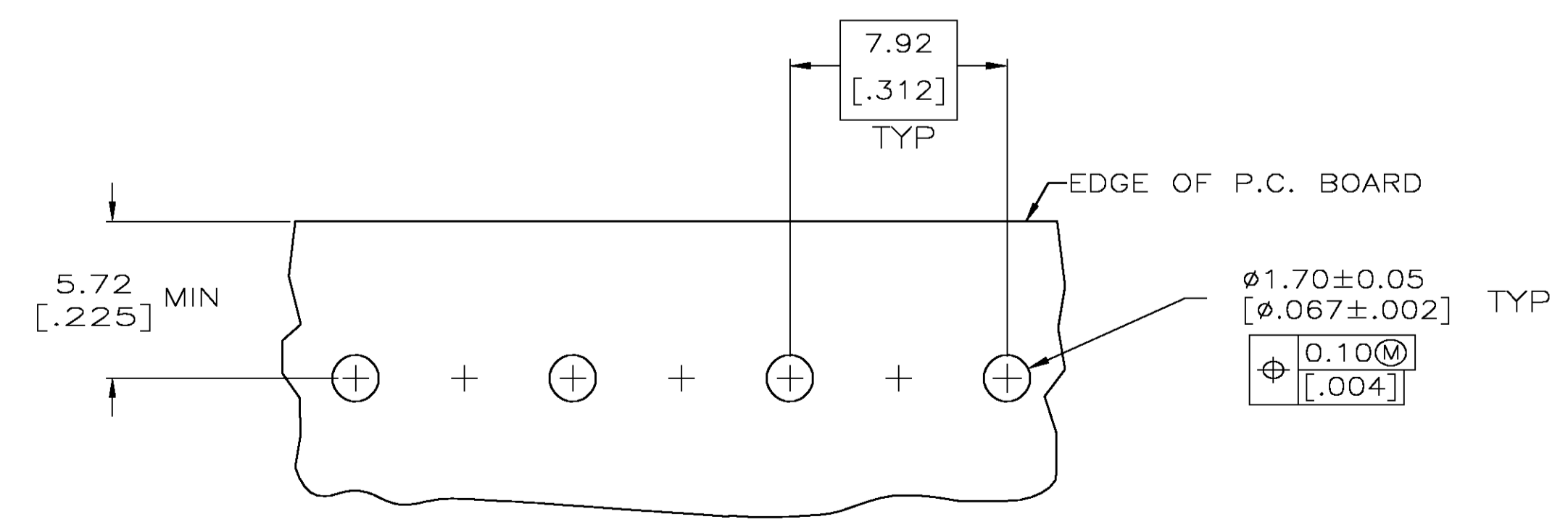
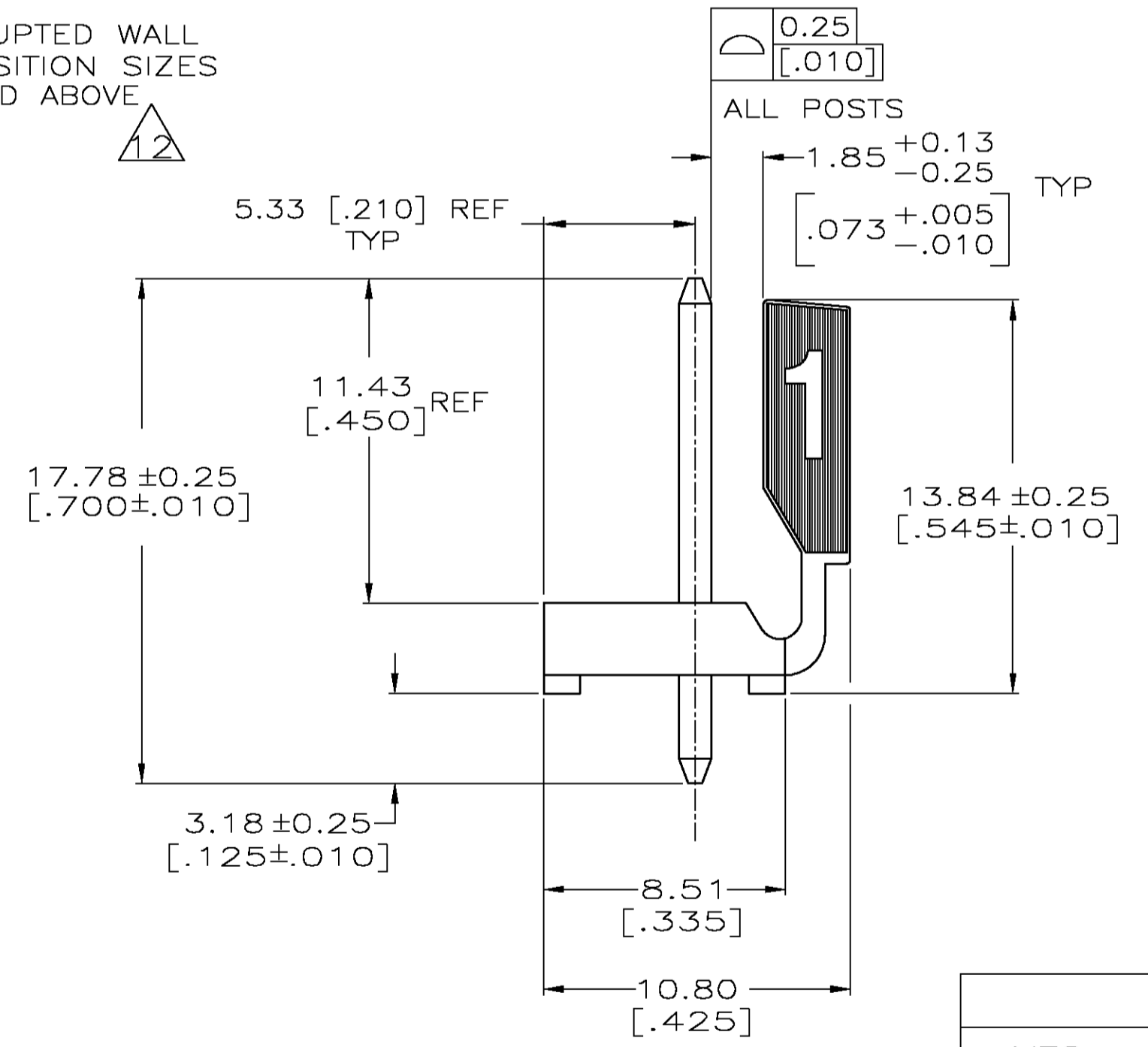
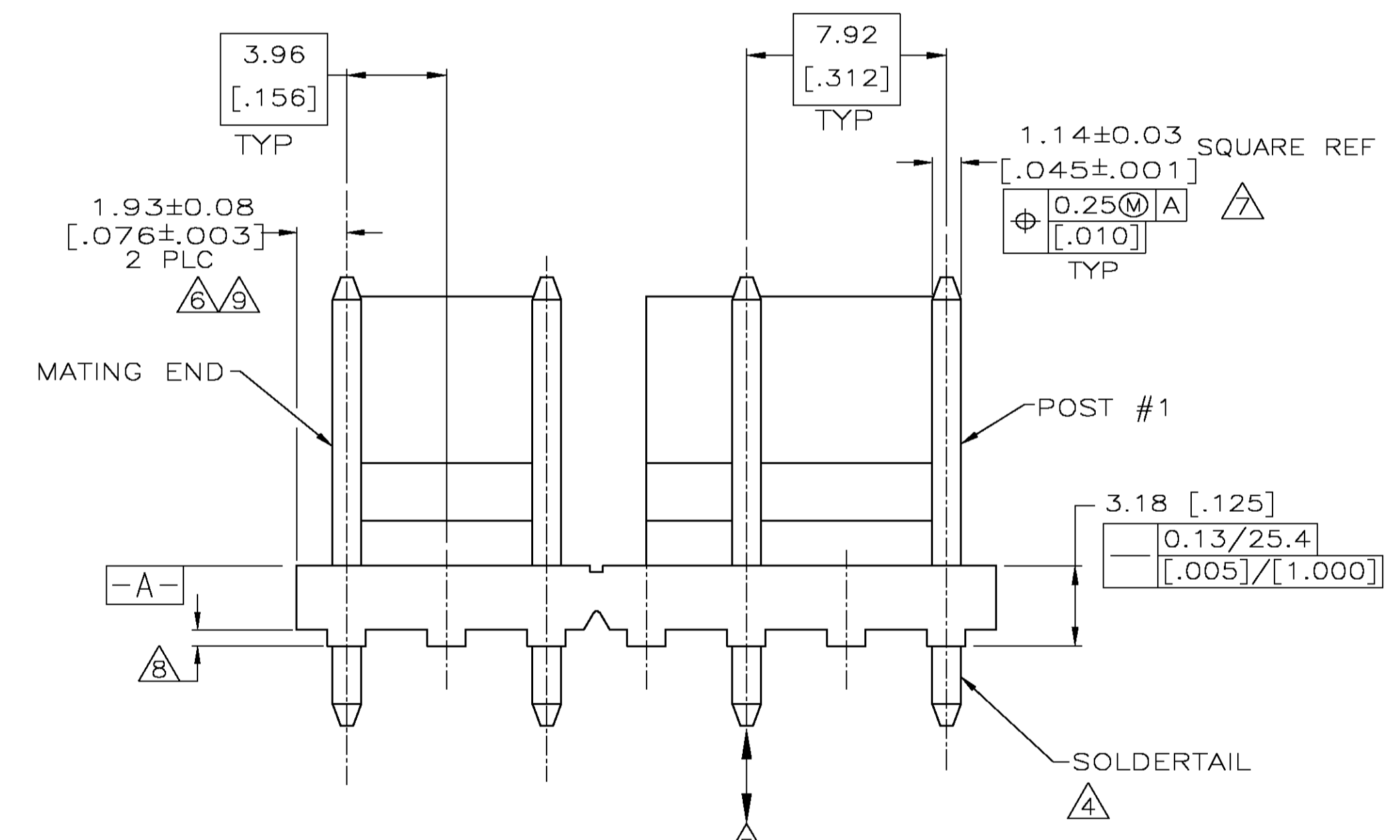

YES	4 & 5	27.61	[1.087]	7	3-647178-7
NO	4 & 5	27.61	[1.087]	7	647178-7
LEAD FREE	BACK WALL INTERRUPTIONS BETWEEN POSTS	mm	[IN]	NO OF POSITIONS	PART NUMBER

RECOMMENDED MOUNTING HOLE PATTERN FOR 1.57 [.062] THICK P.C. BOARD

METRIC

THIS DRAWING IS A CONTROLLED DOCUMENT.

DIMENSIONS: mm [INCHES]	TOLERANCES UNLESS OTHERWISE SPECIFIED:	DIN S. HOOVER 22-OCT-2004	APPRO D. BOSSI 22-OCT-2004	tyco Electronics Tyco Electronics Corporation Harrisburg, Pa 17105-3608
0 PLC ±	1 PLC ±	2 PLC ±	3 PLC ±	4 PLC ±
ANGLES ±	FINISH 2	NAME ASSEMBLY- MTA .156 HEADER, POLARIZED LOCK, STR .045 SQUARE POST, TIN OR TIN-LEAD PLATED, OMITTED POST #2, 4, & 6, SPECIAL	APPLICATION SPEC	SIZE A1
MATERIAL 1	FINISH 2	WEIGHT	SCALE 5:1	SHEET 1 OF 1
		CUSTOMER DRAWING	REV D	